

INTIEL

THE ELECTRONICS ON YOUR SIDE

Programmable Differential Thermostat
TD-3.1

User's Manual

I. Application

Programmable Differential Thermostat DT-3.1 is used for domestic hot water preparation in water heaters, where the heating energy is provided in combined way, by solar panels (fireplace) and electrical heating elements. It is designed to control the circulation pump operation, installed in the water circuit between the solar panels (fireplace) and the water heater serpentine, thus regulating the heat exchanging between them.

II. Operation

The Thermostat is equipped with two temperature sensors, mounted respectively one in the water heater and the other one in the solar panels. In this way the Thermostat monitors the following parameters:

- 2.1. ΔT , Δt – adjusted and current (real) difference between the water heater and solar panel temperatures. ΔT can be adjusted in the range of 2 up to 20°C. **The default setting is 10°C**
- 2.2. Wb – adjusted temperature level of the water heater to which it can be heated from the solar panels. The temperature can be adjusted in the range between 30 and 90°C. **The default setting is 60°C.**
- 2.3. Tb_{max} – maximum allowed water heater temperature. It can be adjusted in the range between 80 and 100 °C. **The default setting is 95°C.**
- 2.4. Tp_{min} – minimum temperature level of the solar panel. It can be adjusted in the range between 20 and 50 °C. **The default setting is 40°C.**
- 2.5. Tp_{max} – maximum allowed temperature of the solar panel. It can be adjusted in the range between 80 and 110°C. **The default setting is 105°C.**
- 2.6. $Tp_{defrost}$ – defrost temperature level of the solar panel. It can be fixed in the range between 0 up to 10°C. **The default setting is “- -“, without defrosting.**
- 2.7. Tb_{min} – minimum water temperature level in the water heater. It cannot be adjusted. **The default setting is 20°C**

Differential Thermostat DT-3.1 operation depends on the temperature sensor states, as follows:

A) Normal operation

- The circulation pump will be switched on, starting the heating of the water heater in case, there is a positive temperature difference Δt between the solar panels (fireplace) and the water heater, exceeding the preliminary fixed one ΔT with 3°C. The circulation pump will be stopped if Δt decreases until it will be equalized with adjusted ΔT .

- The heating of the water heater at the above mentioned conditions goes on until the water heater temperature will be equalized with the adjusted one Wb . Afterwards, the operation of the circulation pump and respectively, the heating of the water heater will be stopped.

- if at the above mentioned conditions the solar panel (fireplace) temperature decreases bellow Tp_{min} , the circulation pump operation will be stopped, despite of the following conditions are fulfilled $\Delta t > \Delta T + 3^\circ$ and $Tb < Wb$.

- If the solar panel temperature falls down bellow $Tp_{defrost}$, the circulation pump will be started by force, despite of it had been switched off, due to decrease of solar panel temperature bellow Tp_{min} . The default settings of the unit disable its defrost function, which can be enabled by fixing the defrost temperature level described at part 4.3. “Programming of temperatures 2.1 – 2.6”.

- If the water heater temperature at the previous mentioned conditions falls down bellow Tb_{min} , the circulation pump will be stopped as well, thus stopping the defrosting of the solar panel.

B) Emergency operation

- If during water heater warming the solar panel (fireplace) temperature exceeds $T_{p_{max}}$, the circulation pump will be switched on by force in order to obtain the solar panel cooling. The previous mentions will be done despite of the water heater temperature can exceed Wb .

- If at the previous mentioned emergency case, the water heater temperature reaches its maximum allowed temperature level $T_{b_{max}}$, the circulation pump will be stopped despite of this state can causes overheating of the solar panel. In this way the temperature at the water heater has a higher priority compare to the temperature of the solar panel (fireplace).

C) Water tank and solar panel protection

- When the water tank temperature T_b is above the assigned one Wb and in the same time is grater than the solar panel temperature, in terms of preventing water tank overheating the circulation pump will be switched on. Its operation (see the hatched area of the diagram) goes on until the water tank temperature T_b is being decreased to the assigned one Wb . In this case the water tank gives the excessive heat, as it cool itself through the solar panel. When a combine heating with electrical heating elements is being used, then the assignation of the of the electrical part is to be a little bit lower than Wb .

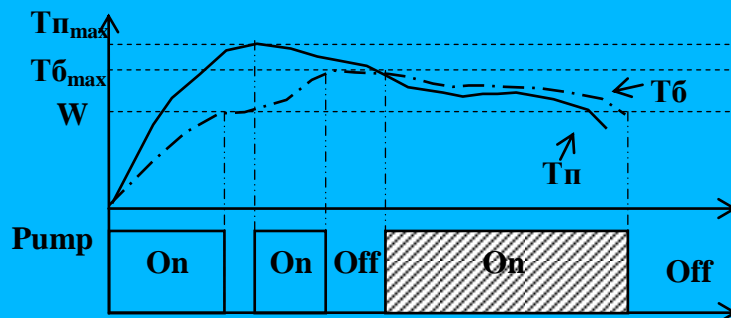

III. Front panel indications

On the front panel are located all elements for control and programming. These are three digital display, ten light indications and two buttons, “SELECT” and “PROGRAM”. The front panel vision is shown on Figure 1 bellow.

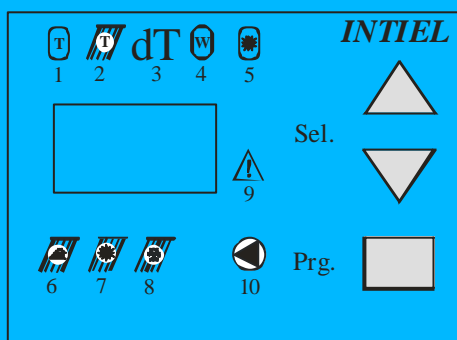

Indications on the digital display	
1	T_b – shows the water heater temperature
2	T_p – shows solar panel temperature
3	ΔT – shows the adjusted temperature difference between the solar panel and the water heater
4	W_b – shows the water heater temperature level which has to be kept
5	T_{bmax} - shows the maximum allowed water heater temperature
6	T_{pmin} – shows the fixed minimum temperature level of the solar panel
7	T_{pmax} – shows the adjusted maximum temperature level of the solar panel
8	T_{pdefrost} – shows the adjusted temperature level for solar panel defrosting
9	Pump – shows the circulation pump operation
10	Alarm – shows emergency operation

IV. Programming

The Thermostat automatically goes into start mode, after connection to the power supply, showing the water heater temperature:

4.1. Inspection of water heater and solar panel temperatures.

When the Thermostat is not in program mode, by consecutively pressing of “SELECT” button the digital display indication is being switched over between the water heater temperature and the solar panel one, activating their relevant indications **T_b** or **T_p**.

4.2. Inspection of temperatures mentioned at points 2.1 – 2.6 (see II. Operation, page 2.)

After pressing “PROGRAM” button the digital display will automatically show the temperature mentioned at 2.1 - **ΔT**. Then, after pressing “SELECT” button five times more the temperatures 2.2 – 2.6 will be indicated. Next pressing of “SELECT” button will return you to position 4.1. (Inspection of water heater and solar panel temperatures). The temperature inspection does not change the current operation of the Thermostat.

4.3. Programming of temperatures 2.1 – 2.6.

The digital display will automatically show the temperature mentioned at 2.1 - **ΔT**, after pressing “PROGRAM” button. The temperature indication will start blinking 10 times, after second pressing of “PROGRAM” button. The adjustment of the same temperature can be done during the blinking time by repeatedly pressing of the “SELECT” button, within the possible adjusted range. If until the 10th blink “SELECT” button is not pressed or “PROGRAM” button is pressed, the last blinking value will be accepted as adjusted one concerning the relevant temperature. If you want to make some corrections concerning just adjusted temperature, you need to press “PROGRAM” button again, thus returning to above mentioned actions.

You can go to next temperature programming by pressing “SELECT” button. The Thermostat will go into start mode after you finish with programming of all temperatures from 2.1 – 2.6 and the new adjusted values will become current. After the adjustment of temperature 2.6 you can return to 4.1 (Inspection of water heater and solar panel temperatures) by pressing “SELECT” button.

V. Emergency alerts

5.1. Indication Alarm

The light indication **Alarm** will be activated in the following cases:

- When the water heater temperature exceeds $T_{b_{max}}$. Then, in addition a light indication **Tb** is activated and the water heater temperature is being shown on the digital display.

- When the temperature of the solar panel or the water heater is negative. In this case, a light indication **Tb** is activated and the negative temperature is being shown on the digital display.

5.2. The solar panel and water heater temperatures are out of preliminary fixed ranges:

- When one of the temperatures is greater than $+125^{\circ}\text{C}$ on the digital display is being indicated “**Hi**”.

- When one of the temperatures is lower than -30°C on the digital display is being indicated “**Lo**”

VI. Wiring

The wiring comprises the connection of temperature sensors, a power supply and the circulation pump according Figure 2. The sensors are Pt1000 – non polar. If necessary, the length of connection cables can be prolonged, considering the total resistance of both cables, concerning indication sensibility of $1^{\circ}\text{C}/4\Omega$. The recommended cable length which do not affect to measurement precision is up to 100m.

Terminals 19 and 20 are inputs for water heater temperature sensor.

Terminals 22 and 23 are inputs for solar panel temperature sensor.

To terminals 6, 7 and 8 are to be connected neutral, phase and earth.

The circulation pump is to be connected to terminals 9, 10 and 11, which are respectively earth, neutral and phase. To terminal 12 (L2) occurs a phase when to terminal 11 (L1) does not, and conversely.

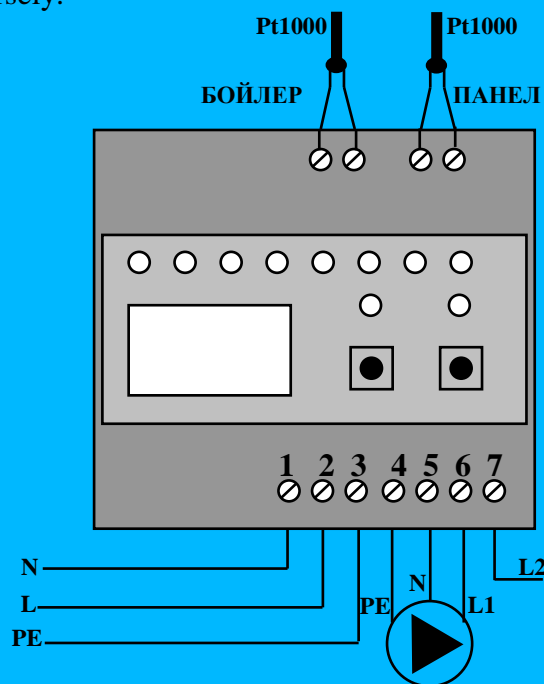
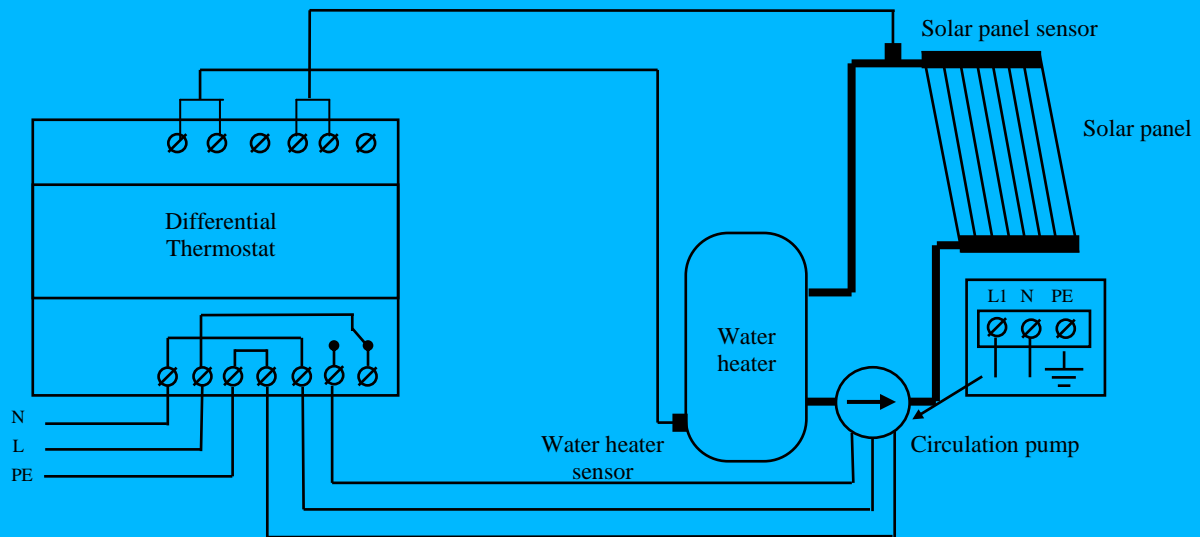

Figure.2

VII. Hydraulic connections

A) Domestic hot water preparation only by solar panel



B) Domestic hot water preparation by solar panel and electrical heating elements

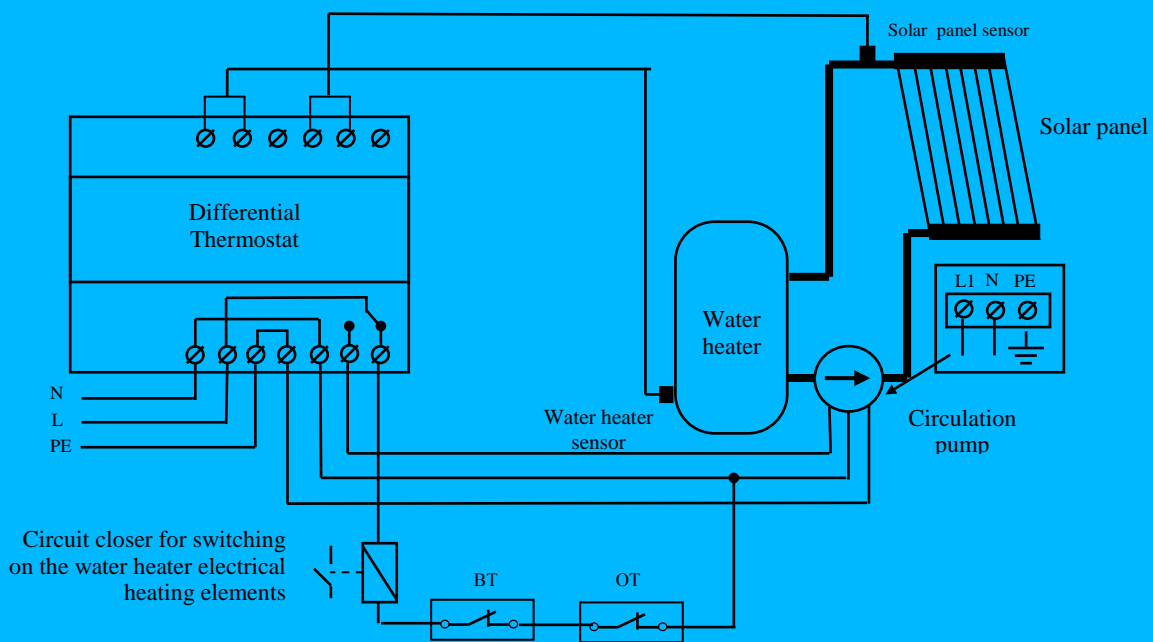

OT - water heater operation thermostat

BT - water heater safety (blocking) thermostat

C) Domestic hot water preparation by a fireplace and a motor actuator “open – close” for the water heater

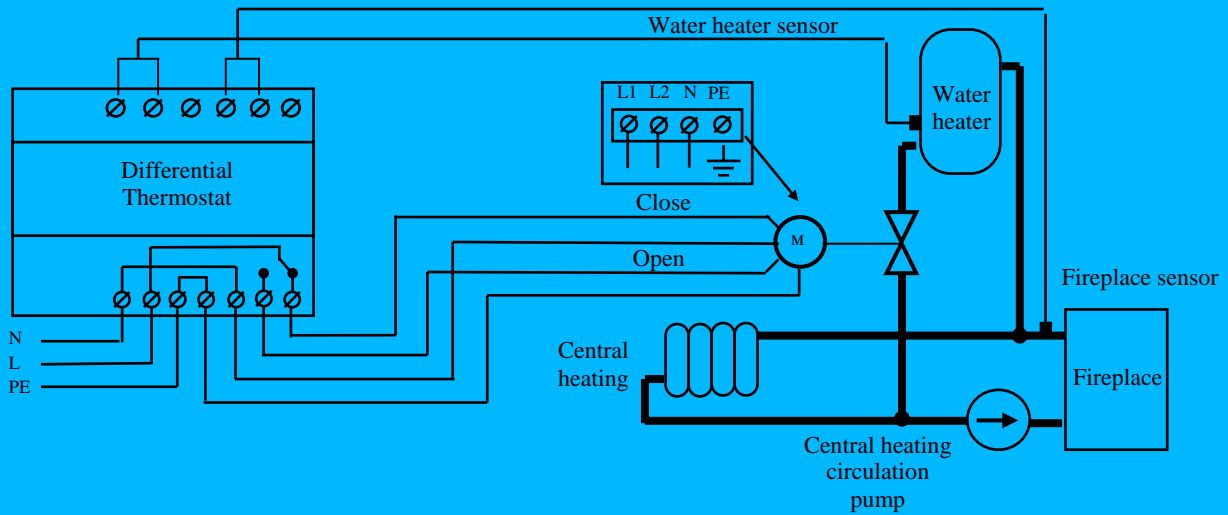

D) Domestic hot water preparation by a fireplace and water heater electrical heating elements

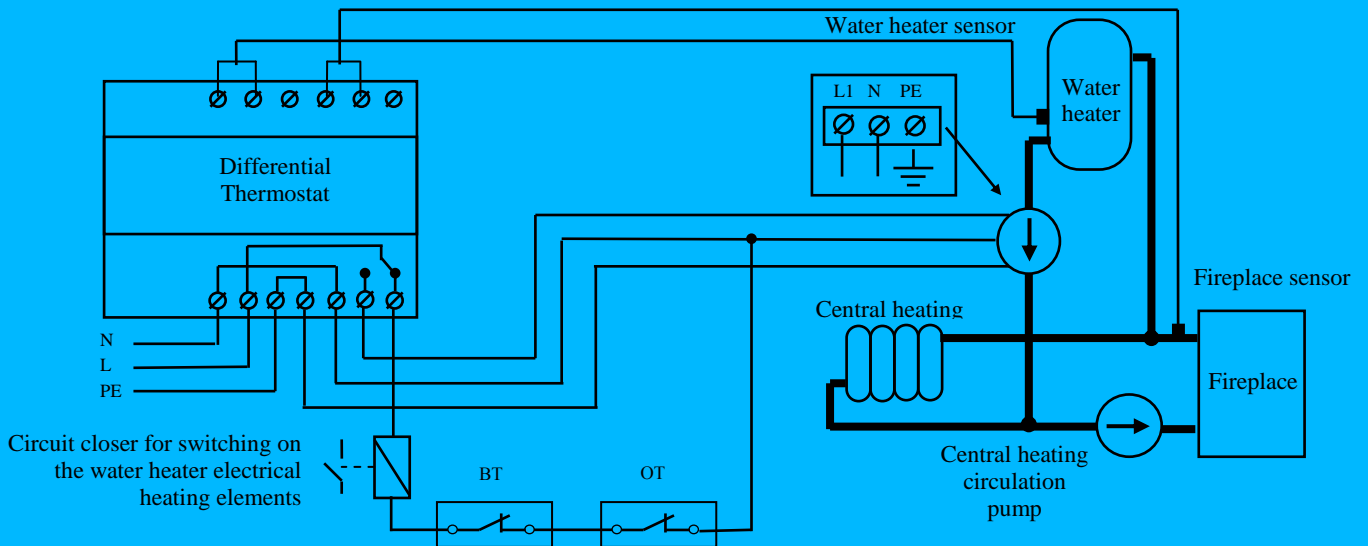

OT - water heater operation thermostat
 BT - water heater safety (blocking) thermostat

Technical data	
Supply voltage:	230V / AC / 50-60Hz
Maximal rated current:	7A / 250V / AC / 50-60Hz
Outputs:	1 standard relay (changeover contacts)
Switch-on difference:	ΔT 2...20°C adjustable
Sensors:	2 temperature sensors Pt1000 (-50° до +200°C)
Sensor current:	2.6 mA
Range of temperature measuring:	from -30 up to +125°C
Digital display:	Three positional
Measurement precision:	1°C
Humidity:	0-80%
Protection:	IP20

VI. Warranty

The warranty period is 24 months following the purchase date of the unit or its installation by an authorized Engineering Company, but not exceeding 28 months after the production date. The warranty is extended to the malfunctions that occur during the warranty period and are result of the production reasons or defective used parts.

The warranty does not relate to malfunctions corresponding to not-qualified installation, activities directed to the product body interference, not regular storage or transport.

The repairs during the warranty period can be done after correct filling of the manufacturer warranty card

Warranty Card

Manufacturer: INTIEL	
Product type	Programmable Differential Thermostat DT-3.1
Production number	
Production date	
Dealer confirmation	
Purchase date	
Invoice number	
Dealer's name, address and stamp	
Seller's name and signature	