

INTIEL

THE ELECTRONICS ON YOUR SIDE

**PROGRAMMABLE CONTROLLER FOR SOLAR
SYSTEMS
DT 3.2.2**

USER'S GUIDE



INTIEL LTD
10, str. Major Kolontaevski
8200 Pomorie
BULGARIA

www.intiel.com

PROGRAMMABLE CONTROLLER FOR SOLAR SYSTEMS

TECHNICAL DESCRIPTION



Safety instructions:

- Before installation, check the integrity of the unit and its connecting wires.
- In case of damaged can not be mounted to the removing of the fault.
- The installation and disassembly of the unit must be carried out by qualified personnel who have previously read the product manual.
- Mount in a dry and ventilated place away from heat sources and flammable gases or liquids.
- Make sure that the mains voltage matches the voltage on the rating plate of the unit.
- Use power consumers that match the power output of the appliance.
- In the event of malfunctioning, switch off the appliance immediately and seek authorized service for repair.
- In case of fire, use a fire extinguisher.
- For the purpose of environmental protection, do not throw away electrical appliances and their packaging marked with a symbol

crossed bin



Contents of the package:

- The controller
- Sensors type Pt 1000-2 pcs.
- User guide (warranty card)

I. Application

The solar controller is integrated into domestic hot water systems in boilers, combined with solar panels (fireplaces) and electric heaters.

It is designed to monitor the differential temperature and to control the operation of a circulation pump mounted in the water circuit between the panels (fireplace, boiler) and the boiler coil. This regulates the heat exchange between them, helping to make the system more efficient.

II. Front panel

The front panel contains the monitoring and control elements. These are graphical (LCD) displays, LED indicators and buttons. The appearance of the front panel is shown in Figure 1.

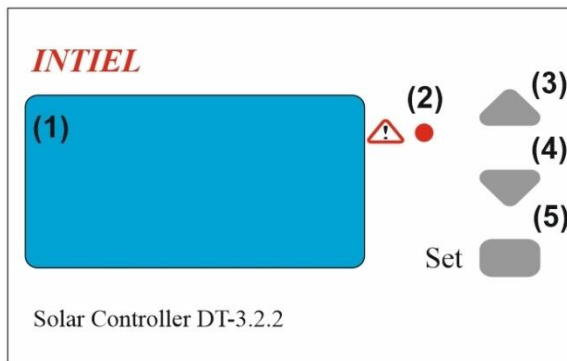

Fig.1

The graphic display (1) is 128x64 pixels and backlit. Provides visual information about the current values of the measured values and the status of the system, through graphic images and symbols (**icons**), as well as the ability to set the controller through a user menu.

LED indication (2) - Alerts for emergency operation.

Adjustment buttons:

- „▲” – (3) scroll up the menu, increase value;
- „▼” – (4) scroll down through the menu, decrease in value;
- „■” – (5) menu access, selection, saving change.

2.1 Display

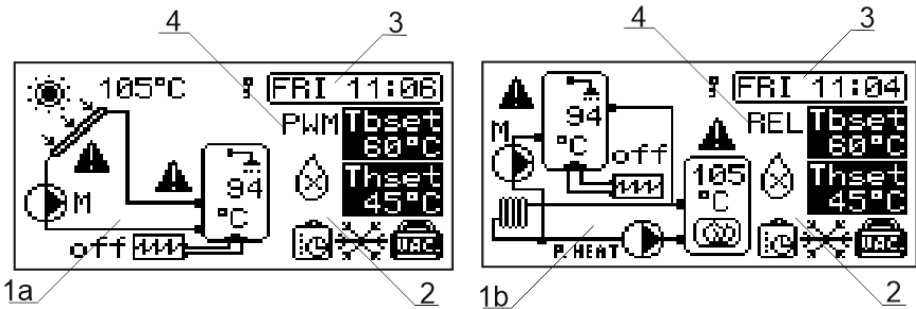

Basic versions of the solar system:

- Heating of a solar panel boiler and electric heaters (1a);
- Heating of the boiler by the fireplace (boiler) and electric heaters (1b).









Schemes should not be considered complete.

Depending on the particular application, there may be additional ones components and safety components that may be required, such as check valves, shut-off valves, etc.

The controller is not a substitute for safety devices.

2. Field of icons, provides additional information about the state of the system (see Table 1);
3. Hour and day of the week field. The date is displayed in the menu only;
4. Pump control type:
 - **REL** – pump control via relay output (terminals 5 and 6). Used for standard pumps. PWM and DCV outputs are off;
 - **PWM** – control of the pump by pulse width modulation (terminals 9 and 10). Used to change the speed of high-efficiency pumps. When a PWM output is switched on, a relay output is also included, which can be used to power the pump;
 - **DCV** – pump control via 0-10V signal (terminals 11 and 12). Used to change the speed of high-efficiency pumps. When the DCV output is switched on, the relay output is also switched on.

Table 1

ICONS	
<i>image</i>	<i>description</i>
	Anti-freeze function enabled
	Triggered function against bacteria "Legionella"
	Warning of a dangerous condition (excessive high or low temperature)
	Mode activated "Holiday"
	Weekly program included
	The menu is locked
	Pump. When the pump is running, the icon rotates.
	Pump. Manual mode

Other display symbols:



solar panel



water heater



fireplace (boiler)



day - indicates the bright part of the day. The time from at sunrise until sunset (light period)



night - indicates the dark part of the day. The time from at sunset until sunrise.

The length of the day and night periods is different and is calculated approximately according to the season and location (latitude) of Sofia.

III. Structure and description of the menu

The graphical mode in which the measured parameters are monitored and the status of the system appears immediately after the operational power is supplied to the controller or when no button is pressed for 30 seconds.

To access the main menu, press the "■" button. It allows you to select a time settings submenu or a system controller submenu. The main menu is as follows:

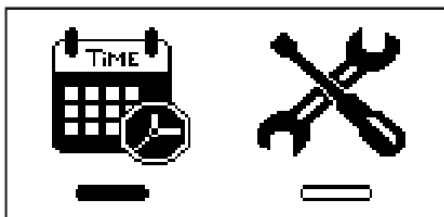

Use the "▲", "▼" buttons to position the selector of the selected submenu and press the button „■” again.

3.1 Time Settings submenu

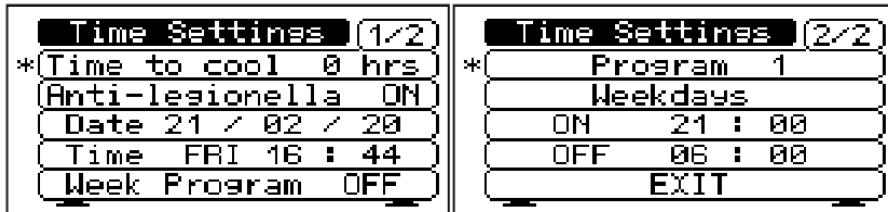

Use the "▲" and "▼" buttons to move the selector * up or down in the menu. To change a setting, press the "■" button. The value will start blinking and then you can select the desired value or parameter with the ▲ and ▼ buttons.

Press the button to confirm and save to memory „■”.

If no button is pressed for 30 seconds, it will exit the menu automatically and return to graphical mode.

Available functions and settings:

- **Time to cool (hrs)**. Time to delay the boiler cooling function to the set T_{bset} temperature. In case the boiler temperature exceeds the set temperature.

The controller will wait for the time specified in this setting to expire and if the condition is met $T_p < T_b - 2^\circ$, will turn the pump on until it reaches T_{bset} . Default setting - 0 hours (no wait).

For example: the boiler was heated to 75 degrees during the day at a set temperature of 60 degrees, after the temperature of the solar panel drops below the

boiler temperature, if no waiting time is set, the pump will start immediately and will try to cool the boiler to the set temperature.

If a delay time of 5 hours is set, the pump will start to cool the water heater at about 22.00 hours and if no hot water has been used during this time. This way instead of cooling the boiler immediately, customers will be expected to use hot water.

The setting "- -" is also possible, in this case the cooling function to the set temperature is switched off;

- **Anti-legionella.** "*Legionella pneumophila*" is a bacterium that is a natural inhabitant of water. The artificial environments in which it can reproduce are systems for domestic hot water, buffers, water heaters, etc., with poor water quality or misuse. Consuming such water can cause serious health problems.

The optimal temperature for the bacterium to develop is 38 ° C, at 50 ° C it stops multiplying and at 70 ° C it is destroyed. The controller's anti-legionella function monitors the temperature in the boiler and if within 7 days the temperature in the boiler did not reach 70 ° C, temporarily raises the T_{bset} and T_{hset} setting to 70 ° C.

Electric heaters are used for this purpose and the time at which the function starts heating is 23:00.

- **Default setting** - ON;

- **Date.** Setting for day, month and year;

- **Time.** Setting the day of the week, hour and minutes for the clock;

- **Week Program.** Weekly Programmer function. Works only at selected value 2 for setting "Heaters ctrl. Type "(see submenu" System Settings "). When activated, it switches on the electric heaters at the selected time interval until T_{hset} is reached. For the rest of the time, the heaters can only be switched on if the temperature in the boiler goes down to values below T_{bmin} . **Default setting** - OFF;

- **Program.** Program number. Up to 7 stand-alone weekly programs can be set up;

- **Select days of the week that a weekly program is active:**

- **None** - the weekly program is deactivated;

- **All days** - the weekly program is active on all days of the week;

- **Weekdays** - the weekly program is active for days Monday through Friday;

- **Weekend** weekly program is only active on Saturdays and Sundays;

Monday, Tuesday, Wednesday, Thursday, Friday, Saturday, Sunday - the ability to choose any day of the week;

- **ON.** Start the active interval of the weekly program. The heaters will be turned on until T_{hset} is reached;

- **OFF.** End of the active interval of the weekly program. Heaters are only allowed at $T_b < T_{bmin}$.

If the switch-on time in the same program coincides with the switch-off time, switching off takes priority. If the time of inclusion coincides with two (or more) programs, the assignment for the first one is valid.

For example:

P1 time ON = P1 time OFF - will be valid P1 OFF

P1 time ON = P2 time ON - will be valid P1 ON

3.2 System Settings submenu

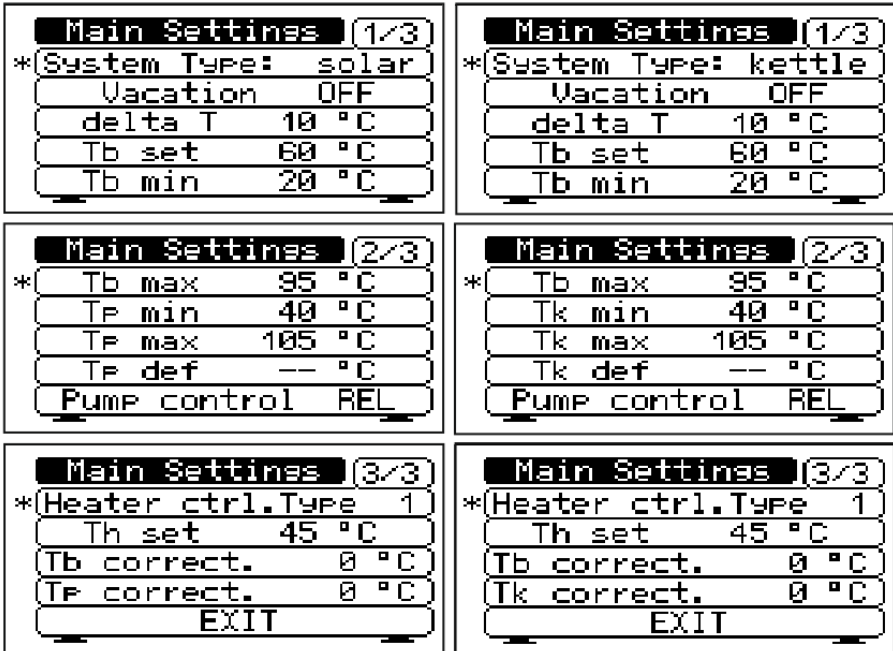

Use the "▲" and "▼" buttons to move the selector * up or down in the menu. To change a setting, press the "■" button. The value will start blinking and then you can select the desired value or parameter with the ▲ and ▼ buttons.

Press the button „■" to confirm and save to memory.

If no button is pressed for 30 seconds, it will exit the menu automatically and return to graphical mode.

Available settings:

- System Type. Choosing a principle hydraulic scheme for the graphics mode.

There are two types of schemes:

solar - Heating of solar water heater and electric heaters.

kettle - Heating of the boiler by the fireplace (boiler) and electric heaters.

- **Vacation.** Vacation mode. Intended for cases where the consumption of hot water from the boiler is not used for a long time. Default OFF;

- **delta T (ΔT).** Set difference between panel and boiler temperatures (differential difference). It can be set between 2 and 20 °C. The default setting is 10 °C. The actual difference will be denoted by Δt .

- **Tbset.** Set temperature in the boiler to which it can normally be heated by solar panels (fireplace, boiler). It is set in the range from 10 to 80°C.

- Default setting is 60 °C;
- **Tbmin**. Minimum temperature in the boiler below which the defrosting of the panel is stopped. It is set in the range from 10 to 50°C. The default setting is 20 ° C;
- **Tbmax**. Critical, maximum allowable temperature in the boiler. It is set between 80 and 100 ° C. The default setting is 95 ° C;
- **Tpmin (Tkmin)**. Minimum temperature of solar panels.
It is set in the range from 20 to 50 ° C. Default setting is 40 ° C;
- **Tpmax (Tkmax)**. Maximum permissible temperature of solar panels (fireplace, boiler). It is set between 80 and 110 ° C. Default setting 105 ° C;
- **Tpdef**. Defrosting temperature of solar panels. It is set in the range -20 to 10 ° C.
Default setting without defrost - -;
- **Pump control**. The pump type determines how the pump is controlled and its speed.

The following settings are possible:

- **REL** - standard pump included at the relay output;
- **PWM** - high-efficiency pump that is controlled by a pulse-width signal;
- **DCV** - highly effective pump which is controlled by a signal 0-10V.
- **Heater ctrl. Type**. Determines the algorithm by which electric heaters will be controlled. The following settings are possible:
 - 1 - Electric heaters are prohibited while the circulation pump is running. The controller can switch them on until Thset is reached but only if the pump has not been running for more than 10 minutes;
 - 2 - the controller switches on the electric heaters according to the set weekly program until reaching Thset;
 - 3 - electric heaters are allowed to reach Thset, regardless of the operation of the circulation pump;
 - 4 - Electric heaters are prohibited.
- **Thset**. Set temperature in the boiler to which it can be heated by electric heaters. It is set in the range from 5 to Tbset-5 ° C. When changing the setting Tbset, if the above condition can not be met, the controller automatically adjusts the Thset. The default setting is 45 ° C;
- **Tb correct**. Correction of the reading from the boiler temperature sensor;
- **Tp correct (Tk correct)**. Correction of the reading from the panel temperature sensor (fireplace, boiler).

The temperature reading can be adjusted by **Tb correct** and **Tp correct**.

The setting is in the range -10 to + 10 ° C. The default is 0 ° C.

3.3 Lock menu

The menu can be locked to prevent inadvertent changes to settings. This is done by simultaneously pressing and holding for more than 3 seconds the "▲" and "▼" buttons. After releasing the buttons, a "key" icon appears on the display indicating that the security is activated.

To unlock the menus, the "▲" and "▼" buttons must be pressed and held again for more than 3 seconds.

Table 2

PARAMETER				
<i>Designation</i>	<i>Description</i>	<i>Level</i>	<i>Default setting</i>	<i>Customization</i>
ΔT	Set the temperature difference between the solar panels and the boiler	2 ÷ 20° C	10° C	
Tbset	Set temperature in the boiler to which it can normally be heated by solar panels (fireplace, boiler)	10 ÷ 80° C	60° C	
Tbmin	Minimum temperature in the boiler below which the defrosting of the panels ceases	10 ÷ 50°C	20° C	
Tbmax	Maximum allowable temperature in the boiler.	80 ÷ 100°C	95° C	
Tpmin	Minimum temperature of solar panels.	20 ÷ 50° C	40° C	
Tkmin	Minimum boiler temperature (fireplace)	20 ÷ 50° C	40° C	
Tpmax	The maximum permissible temperature of solar panels	80 ÷ 110°C	105° C	
Tkmax	Maximum permissible temperature of the boiler (fireplace)	80 ÷ 110°C	105° C	
Tpdef	Temperature at which the defrosting of the solar panels is switched on.	-20 ÷ 10°C	--	
Pump control	Method of controlling the circulation pump	REL, PWM, DCV	REL	
Heater ctrl. Type	An algorithm for controlling electric heaters	1 ÷ 4	1	
Tb correct	Correction of the indication temperature Tb	-10 ÷ 10°C	0° C	
Tp correct	Correction of the indication temperature Tb/ Tp(Tk)	-10 ÷ 10°C	0° C	
Time to cool	Cooling delay time to set temperature Tbset.	0 ÷ 5ч. or „-“	0ч.	
Anti-legionella	Protection against Legionella bacteria	ON/OFF	ON	

IV. How it works

The operation of the controller is determined depending on the set parameters and the measured temperature of the solar panel and the boiler as follows:

A) Normal operating modes

- If the differential temperature Δt of the solar panel (fireplace, boiler) and the boiler is greater than the set point $\Delta T + 2^\circ \text{C}$, the pump is switched on at maximum speed and the boiler is heated from the panels. In the process of heating the boiler Δt decreases. Once the actual Δt is aligned with the set ΔT .

Depending on the pump control mode selected, the following controller reactions are possible:

- **REL** – at certain intervals, a start and stop signal from the relay output is sent to the pump. The work and pause intervals depend on the difference between ΔT and Δt . The greater the differential difference, the interval for when the pump is on is longer and the pause is shorter. When Δt becomes equal to or less than zero, the pump stops. Adjustment is with a period of 600s.
- **PWM** – The pump speed is controlled by a pulse width signal, depending on the difference between ΔT and Δt .

The greater the differential difference, the higher the pump speed. When Δt becomes equal to or less than zero, the pump stops. *For example, when setting the set point $\Delta T = 10^\circ \text{C}$, the controller measured a real differential difference $\Delta t = T_p - T_b = 5^\circ \text{C}$, then the signal supplied to the pump will have a fill factor of 50%, ie. it will run at 50% of its maximum speed.*

- **DCV** – The pump speed is controlled by a signal of 0-10V (0% to 100% speed) and depends on the difference between ΔT and Δt . The greater the differential difference, the higher the pump speed. When Δt becomes equal to or less than zero, the pump stops.

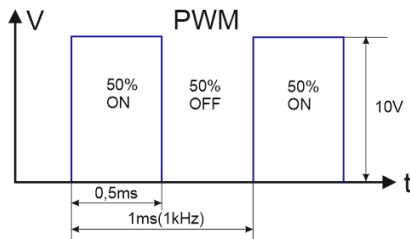

- The boiler is heated under the above conditions only until the temperature in the boiler is equal to the set **T_{bset}**, after which the pump is switched off and the heating is stopped;

- If the temperature of the panels (fireplace, boiler) falls below T_{pmin} , the pump operation is prohibited, even though the conditions $\Delta t > \Delta T + 2^\circ$ and **T_b** $< T_{bset}$ may be present;

- At the temperature of the panels below T_{pdef} and the anti-freeze function enabled, the pump is forced to start, even though it was switched off due to the temperature drop below T_{pmin} ;

- If in the previous mode the temperature of the boiler becomes lower than **Tbmin**, the pump is switched off by stopping the defrosting of the panels;
- The heating of the boiler by the electric heaters is controlled according to the selected setting for **Heater ctrl**. Type (*see section 3*).

In case of defrosting of the panels, the heaters are allowed at the boiler temperature below **Tbmin**, only for the selected system - "*solar*".

B) Vacation mode

The mode is intended for cases when no hot water is consumed from the boiler for a long time. When activated, the set boiler temperature is set to 40 ° C and the start of the heaters is forbidden (except when the Anti-legionella option is enabled). The pump is switched on when necessary to prevent the panel / **Tpmax** / from overheating.

C) Emergency modes

- If during the boiler heating process the temperature of the panels (fireplace, boiler) exceeds **Tpmax** (**Tkmax**), the pump is forced to cool the panels. This is done even though the temperature in the boiler may exceed **Tbset**;

- If in the above emergency mode the temperature in the boiler reaches the critical maximum value **Tbmax**, the pump is switched off even though this may cause the panels to overheat. Thus, the temperature in the boiler is of higher priority;

- When the temperature of the water heater **Tb** is above the set **Tbset** and when the temperature of the solar panels **Tp** falls below the temperature of the water heater, the pump is switched on until the temperature of the water heater **Tb** drops to the set **Tbset**.

This cooling can be delayed from 0 to 5 hours. Sets using the **Time to cool** parameter (the default setting is 0). When combined heaters with electric heaters are used, the **Thset** reference must be lower than **Tbset**.

D) Manual pump mode

The pump is switched on and running at maximum speed without taking into account current settings and measured temperatures.

Manual mode can only be used by qualified personnel for short tests.

Activation is performed by simultaneously pressing and holding down the "▲" and "▼" buttons for more than 3 seconds. The letter "M" will be displayed next to the pump symbol (*see Table 1*).

V. Emergency alarm conditions

5.1 Light signaling.



LED shall be activated for warning in the following cases:

- when the temperature in the boiler exceeds **Tbmax**;
- when the temperature of the panels is greater than the maximum **Tpmax** or with activated defrost **Tpdef**;

5.2 Signaling related to temperature sensors.

Temperature range of measurement is -30 ° to + 140 ° C.

In the case of a faulty sensor or a measured temperature outside the range, the temperature value shall be indicated in the place:

- "Hi" Temperature higher than + 140 ° C or intermittent sensor.
- "low" Temperature lower than -30 ° C or short sensor.

VI. Electrical connection

Electrical connection includes sensor connection, mains supply, controlled pump (and electric heaters) according to **Figure 2**

If necessary, the connecting cables of the sensors can be extended, the length of the cables does not significantly affect the measurement. The recommended maximum length that does not affect the measurement is up to 100m.

Terminals 13, 14 are the sensor input from the panels (fireplace, boiler), terminals 15, 16 are sensor input from the boiler. The sensor type is Pt-1000. These types of sensors are non-polar and the direction of connection is not important.

Terminals 1 and 2 are fed respectively by phase and zero from the mains.

The electrical heaters are connected to terminals 3 and 4.

It should be borne in mind that this is an operational signal.

An additional contactor (shown in Schemes B and D) must be installed to control the electric heaters.

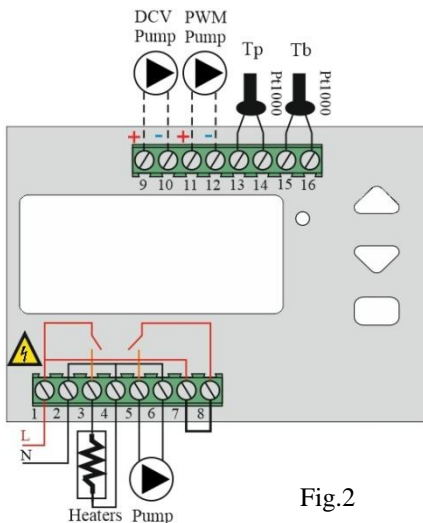

Fig.2

Connection of standard pump to terminals 5 and 6. Phase exits on terminal 5 respectively and at terminal 6 - zero. Terminals 7 and 8 must be bridged if the pump is supplied with a voltage of ~ 220V.

Special (high-efficiency pumps):

- Pumps operated with 0-10V signal, to terminals 9/+ and 10/-;
- PWM controlled pumps to terminals 11/+ and 12/-.

The relay output - terminals 5 and 6 can be used to supply the high-efficiency pumps. At 0% for PWM and 0V for DCV, the pump is powered through terminals 5 and 6 for 10 minutes. After this time, the voltage is removed.

Caution: In order to remove the static electricity stored in solar panels, it is imperative that they and the metal structure be earthed. Otherwise there is a risk of damage to the sensors as well as to the controller itself.

VII. Exemplary hydraulic connection diagrams

A) Heating the boiler only from solar panels

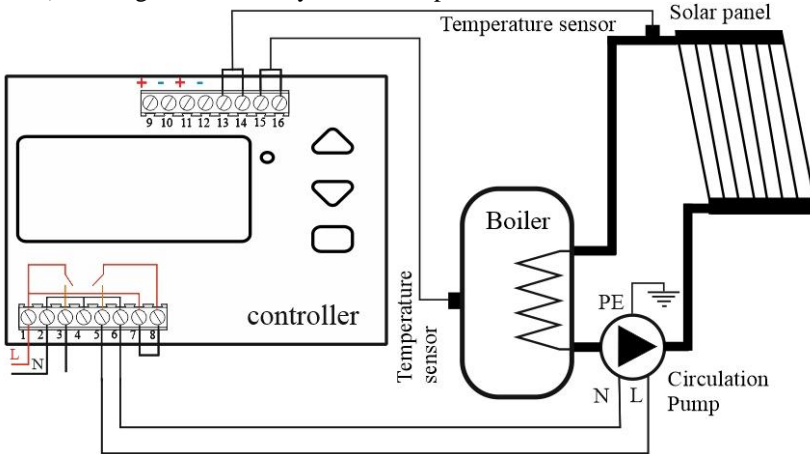

B) Heating of the solar panel water heater and electric heaters

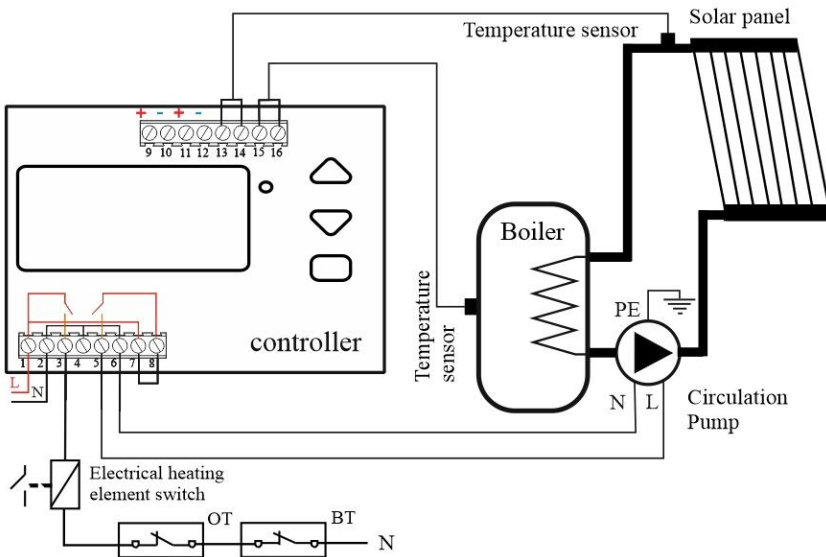

RT - working thermostat of the boiler

BT - blocking thermostat of the boiler

C) Heating of the boiler only by the fireplace and magnet valve "open" - "close" for the boiler

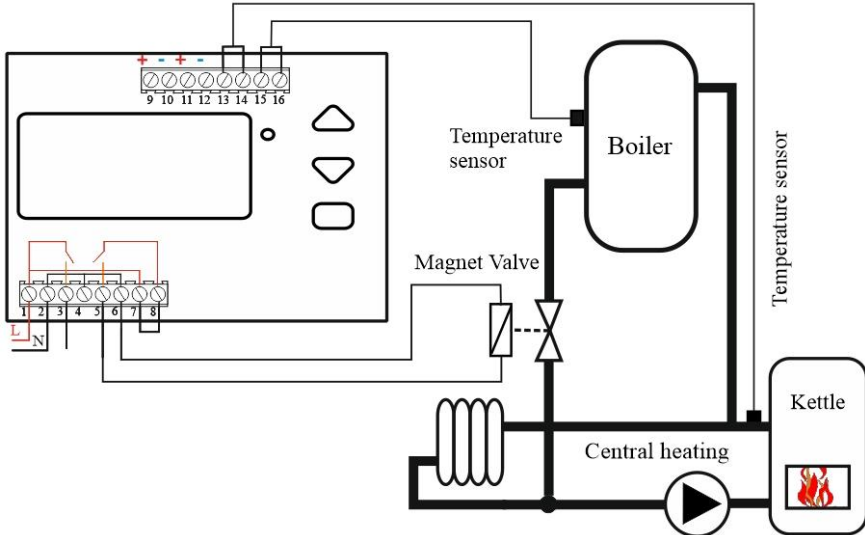

D) Heating of the boiler by the fireplace and electric heaters

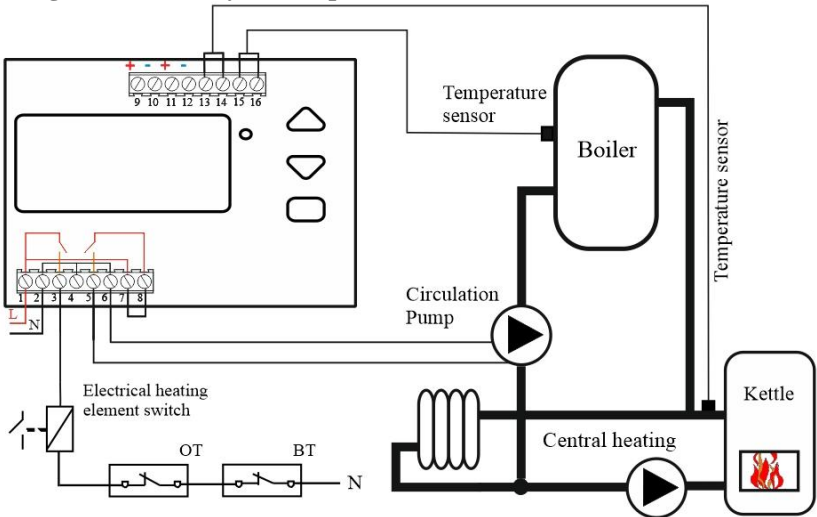

RT - working thermostat of the boiler
 BT - blocking thermostat of the boiler

8. Technical data

Power supply	~ 230V (+/- 10%) / 50-60Hz
Switching current	3A / ~ 250V / 50-60Hz
Number of output contacts	two relay
Output signal PWM frequency	1 kHz level 10V (20mA)
Output DCV signal	0 - 10V (20mA) 10% tolerance
Differential temperature	2 ° - 20 ° C
Sensors: Pt1000	(-50 ° to + 250 ° C)
Current through the sensor	1mA
Measuring range	-30 ° to + 140 ° C
The display is	128 x 64 pixel graphic
Unit of measurement	1 ° C
Environmental temperature	5 ° - 35 ° C
Environmental Humidity	0 - 80%
Degree of protection	IP 20

Temperature / resistance ratio of Pt1000 sensors											
°C	0	10	20	30	40	50	60	70	80	90	100
Ω	1000	1039	1077	1116	1155	1193	1232	1270	1308	1347	1385

VIII. Warranty

The warranty period is 24 months following the purchase date of the unit or its installation by an authorized Engineering Company, but not exceeding 28 months after the production date. The warranty is extended to the malfunctions that occur during the warranty period and are result of the production reasons or defective used parts.

The warranty does not relate to malfunctions corresponding to not-qualified installation, activities directed to the product body interference, not regular storage or transport.

The repairs during the warranty period can be done after correct filling of the manufacturer warranty card